

Contract- No: DMKO - 6 / 99045		Consortium : TAKRAF - BBC	
Checked by:	Checked by:	Checked by:	Checked by:
Superseded by:	Superseded by:	Superseded by:	Superseded by:
Without sep. parts list	Scale	Dept. resp.	
A 83-12-16	B 84-01-30	1-339 240	
Doc. type		Format	Lang.
A12		01	
BBC		B.W.E. SR5 2000	
SOUTH FIELD 2		MAIN BUSBAR SUBSTRUCTURE	
HIBE 201040		HIBE 201040	

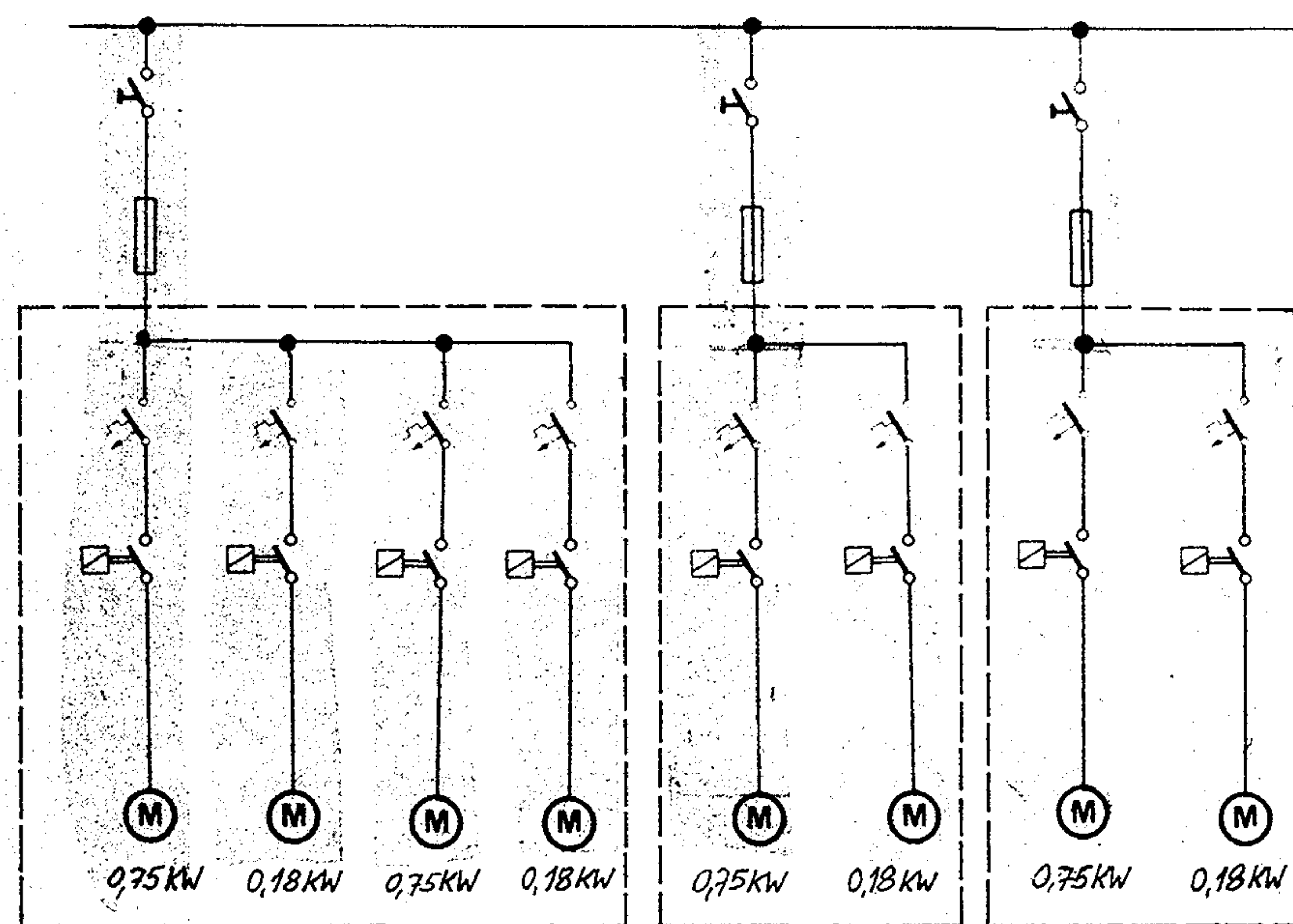
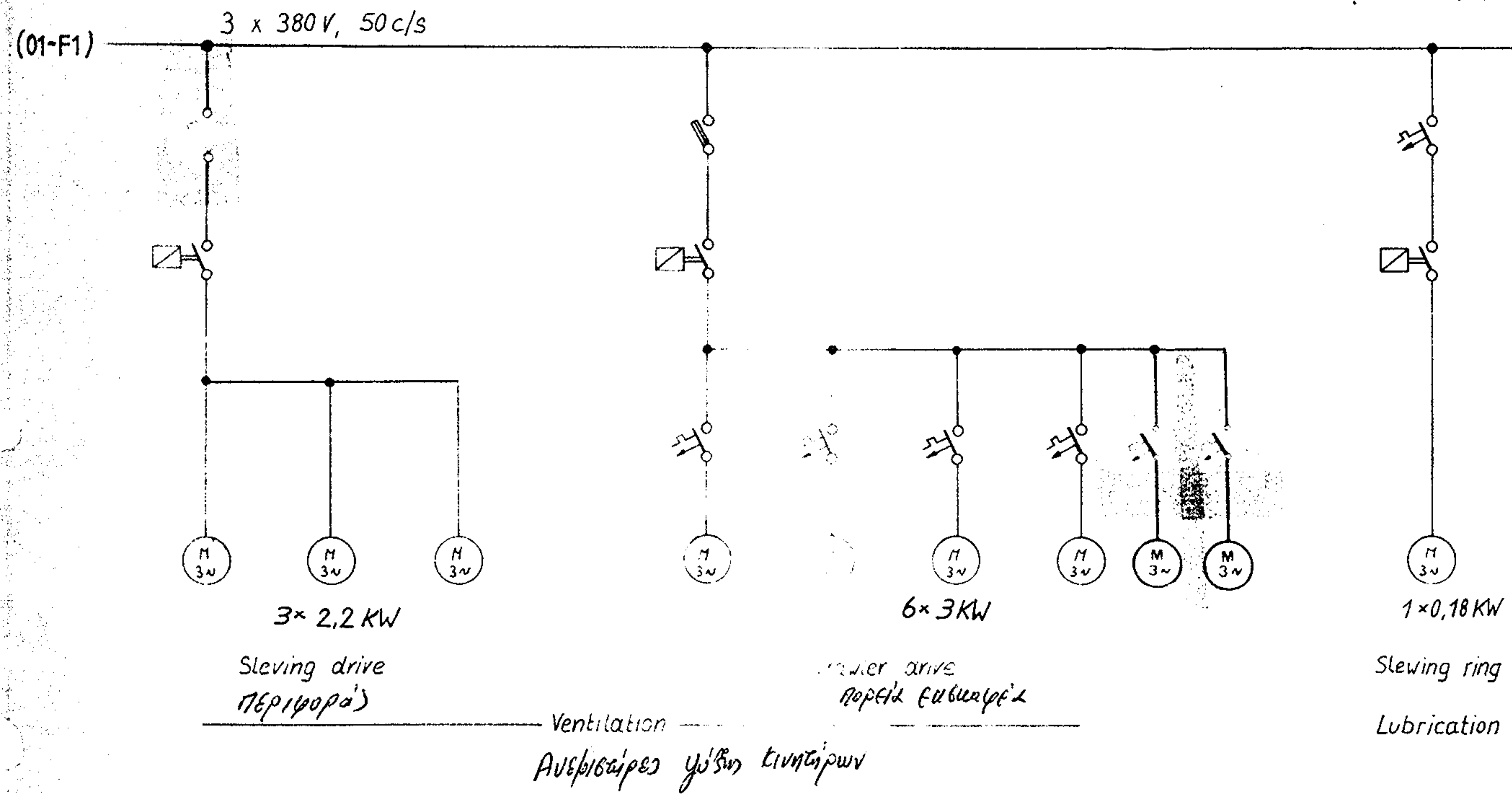

crawler + steering
Привод + Движение

crawler
Привод

crawler
Привод

Two system greasing

2 Lubrifikatsiya

Contract - No: DMKO - 6 / 99045				Consortium : TAKRAF - BBC				
Drawn	Checked	Std checked	Released	Without sep. parts list <input type="checkbox"/>				
Derived from	Super-seeded	Superseded by	Scale	Sep. PL same No <input type="checkbox"/>				
A 83-12-19				Sep. PL other No <input type="checkbox"/>				
B 84-01-30				Dept. resp.				
Title			1-339 240	Doc type	Format	Lang.	Sh No	No sh
BBC			B.W.E. SRs 2000	A 2			02	
			SOUTH FIELD 2	HIBE 201040				
			MAIN BUSBAR SUBSTRUCTURE					

B.WE. SUBSTRUCTURE 380 V. 50 c/s

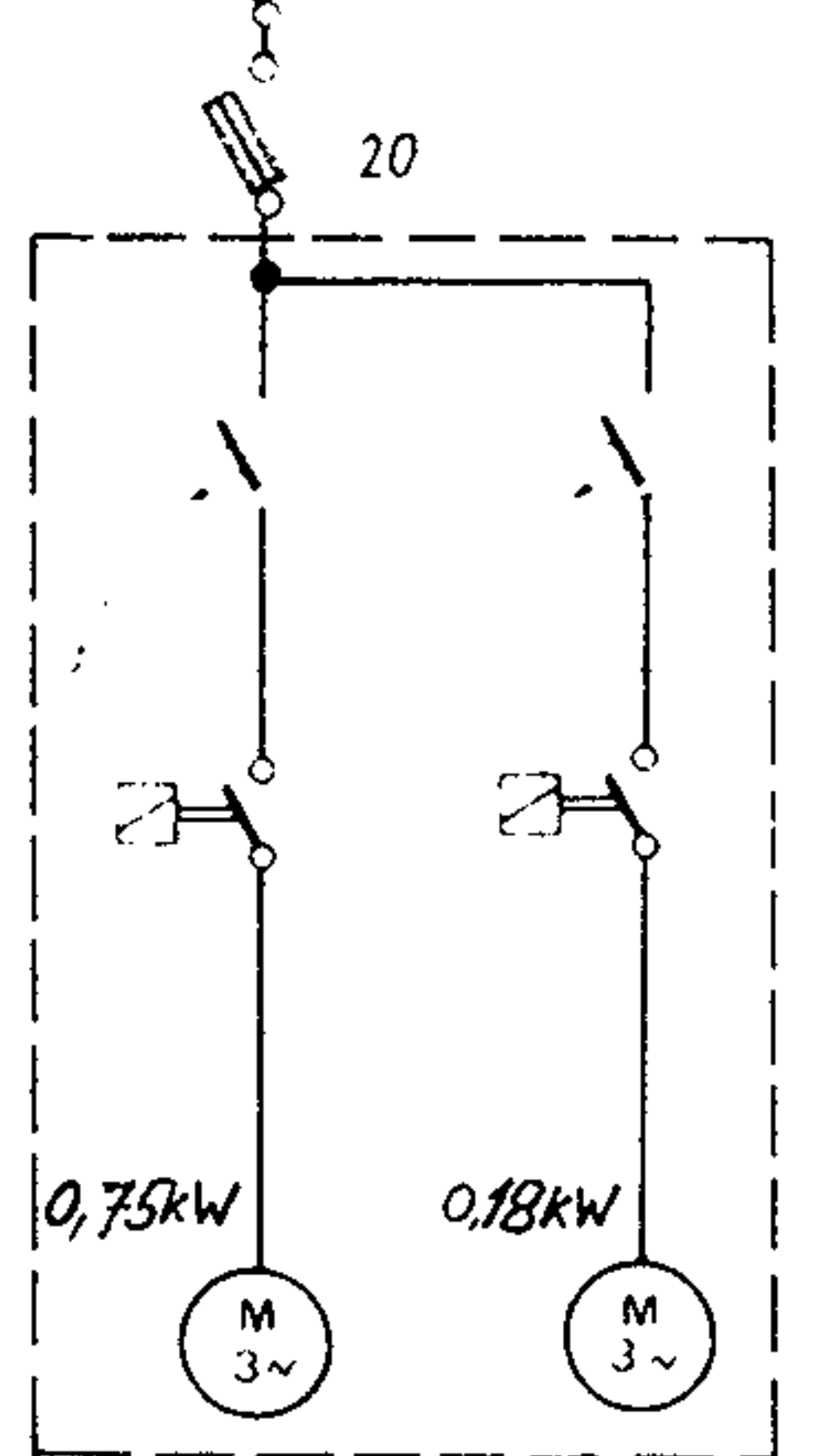



Contract - No: DMKO - 6 / 99045
 Consortium - TAKRAF - BBC

Drawn	Checked	Superseded	Released
Derived from	Super sedes	Superseded by	Without sep. parts list <input type="checkbox"/>
Mod A 83-12-19	Mod B 84-01-30	Mod C 84-01-11	Scale
Mod D 85-08-06			Rece. office
Title: B.WE. SRs 2000 SOUTH FIELD 2 MAIN BUSBAR LOADING UNIT			Dept resp
1-339 240			Doc type
BBC BROWN BOVERI			Format
			Lang
			St. No
			No. st
			HIBE 201 040



Boom hoist drives
Bipa-páira K/T

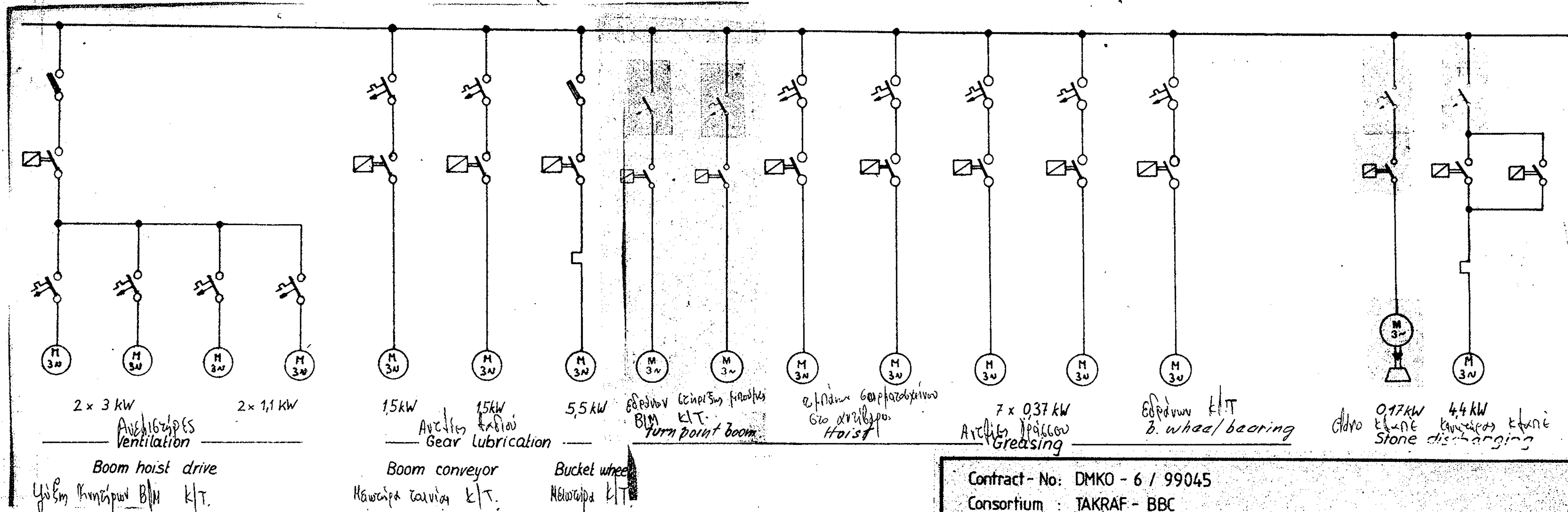

Contract - No: DMKO - 6 / 99045
 Consortium : TAKRAF - BBC

Revised	Superseded by	Revised	Without sep. parts list
A 83-12-19		Scale	Sep. PL same No.
B 84-01-30			Sep. PL other No.
		Dept. resp.	
Doc. type		Format	Lang.
A12			04

1-339 240

BBC
 B.W.E. SRs 2000
 SOUTH FIELD 2
 MAIN BUSBAR SUPERSTRUCTURE

HIBE 201040

3 x 380V, AUX. BUSBAR "A" SUBSTRUCTURE and LOADING UNIT

07-E8

Depart. Aux. busb. "A" Superstructure

M 3N
22 kW

COMPRESSOR
Компрессор

SPARE

M 3N
22 kW

COMPRESSOR
Агрегат (1140 м³)

CABLE
DRUM

Spare

Spare

contr. volt. 220V AC

Contr. volt. 60V DC

Contr. volt. 24V DC

Emerg. stop

Lighting outside

3 x 380V, AUX. BUSBAR "B" SUBSTRUCTURE

ⓐ

250A

ⓐ

400A

HITE 104 079
- C11

07-B8

Depart. aux. busb. "B" superstructure

06-E8

Depart. aux. busb. "B" loading unit

Happel unit E-house LV

Happel unit E-house HV

Vulcaniz. interm. conveyor

Welding travelling

Welding workshop

Field crawler drive

Field slewing drive

Lighting / socket box E-house LV

Lighting / socket box E-house HV

Lighting / socket box crew room

Lighting / socket Box work shop

Lighting / socket Box Trafo rooms 1250 kVA + 315 kVA

Lighting / socket Box Trafo rooms 3150 kVA, 1250 kVA

Contract - No: DMKO - 6 / 99045
Consortium : TAKRAF - BBC

Drawn	Check- ed	Std checked	Re- leased
Derived from:	Super- sedes:	Superseded by:	Without sep. parts list <input type="checkbox"/>
A 83-12-20 Ad.			Scale
B 84-01-30 Mel.			Sep. PL same No <input type="checkbox"/>
Mod.	Mod.	Mod.	Sep. PL other No <input type="checkbox"/>
			Dept. resp. <input type="checkbox"/>

BBC
BROWN BOVERI

Title
B.W.E. SRs 2000
SOUTH FIELD 2 SUBSTRUCTURE and
AUX. BUSBAR LOADING UNIT

1-339 240

Doc. type Format Ling Sh. No No. sh.
A 2 05

HIBE 201040

HIBE 201040

Für diese Unterlage behalten wir uns alle Rechte, auch für den Fall der Patenterteilung und der Eintragung eines anderen gewerblichen Schutzrechtes, vor. Missbräuchliche Verwendung, wie insbesondere Vervielfältigung und Weitergabe an Dritte ist nicht gestattet; sie kann zivil- und strafrechtlich geahndet werden.

0 50 100

3x380V AUX. BUSBAR „B“ LOAD. UNIT



05-C6

Supply

Vulcaniz. discharge conv.

Vulcaniz. receiving conv.

Welding travelling

Lighting/heat. box Cabin C30

Lighting outside

Emerg stop

Spare

Spare

Spare

Spare

Spare

CONTRACT-NO: DMKO-6 199045				CONSORTIUM: TAKRAF-BBC						
Drawn	Checked	Std checked	Re leased							
Derived from:	Super sedes:	Superseded by:	Without sep. parts list <input type="checkbox"/>							
A 83-12-20 <i>AZ</i>			Scale	Sep. PL same No <input type="checkbox"/>						
B 84-01-30 <i>Mel</i>				Sep. PL other No <input type="checkbox"/>						
C 84-05-17 <i>L</i>				Receiv. office						
Mod.			Dept. resp.							
BBC BROWN BOVERI			Title	1-339 240		Doc. type	Format	Lang.	Sh. No	No. sh
			B.W.E SR _s 2000		A 2		06		HIBE 201 040	
			SOUTH FIELD 2							
			AUX. BUSBAR LOAD. UNIT							

HIBE 201 040

All rights are reserved for this document, even in case of issuance of a patent and registration of another industrial right. Misapplication, in particular reproduction or handing over to third parties is prohibited and actionable under civil and criminal law.

0 50 100

3 x 380V, AUX. BUSBAR "A" SUPER STRUCTURE

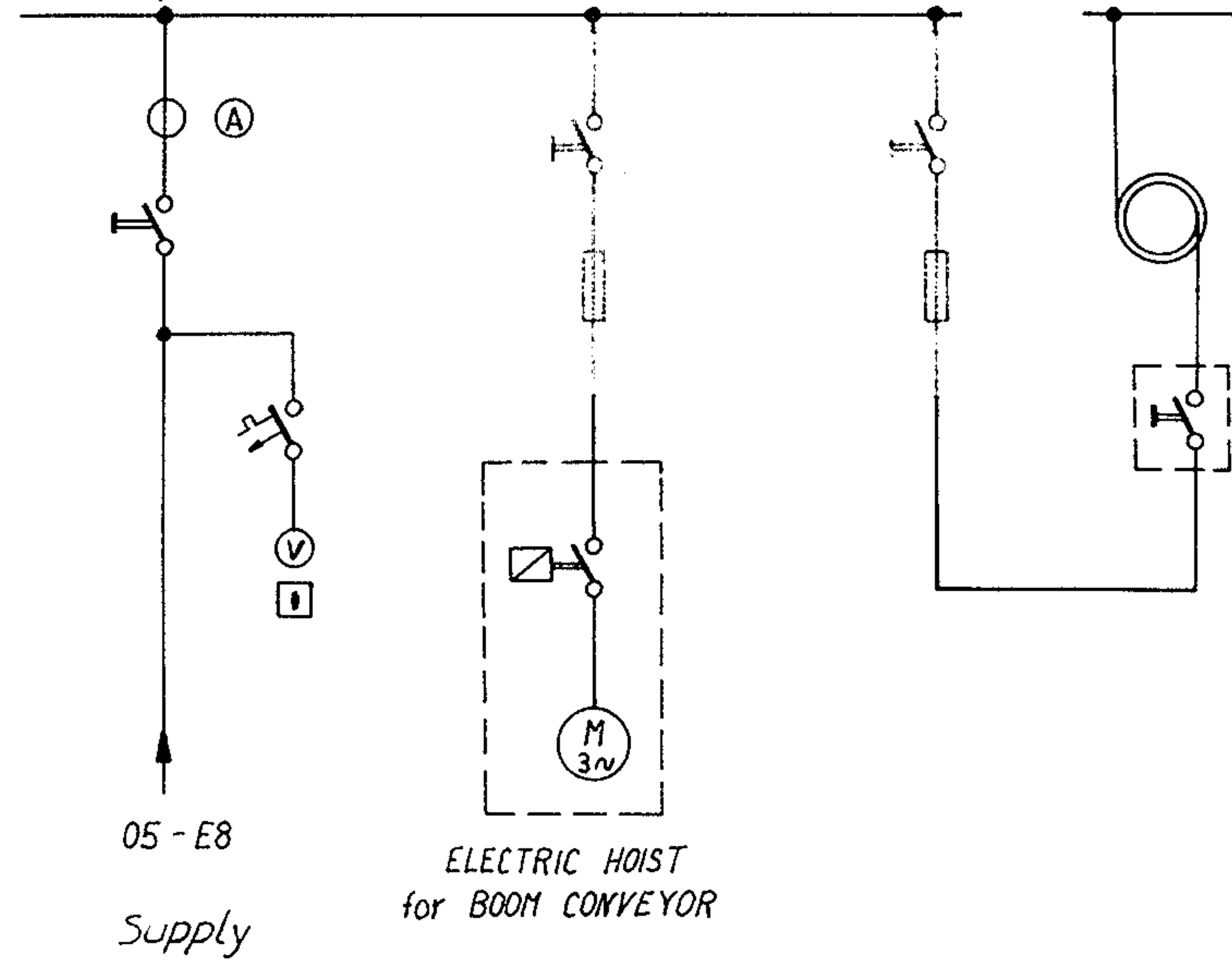

Maintenance crane

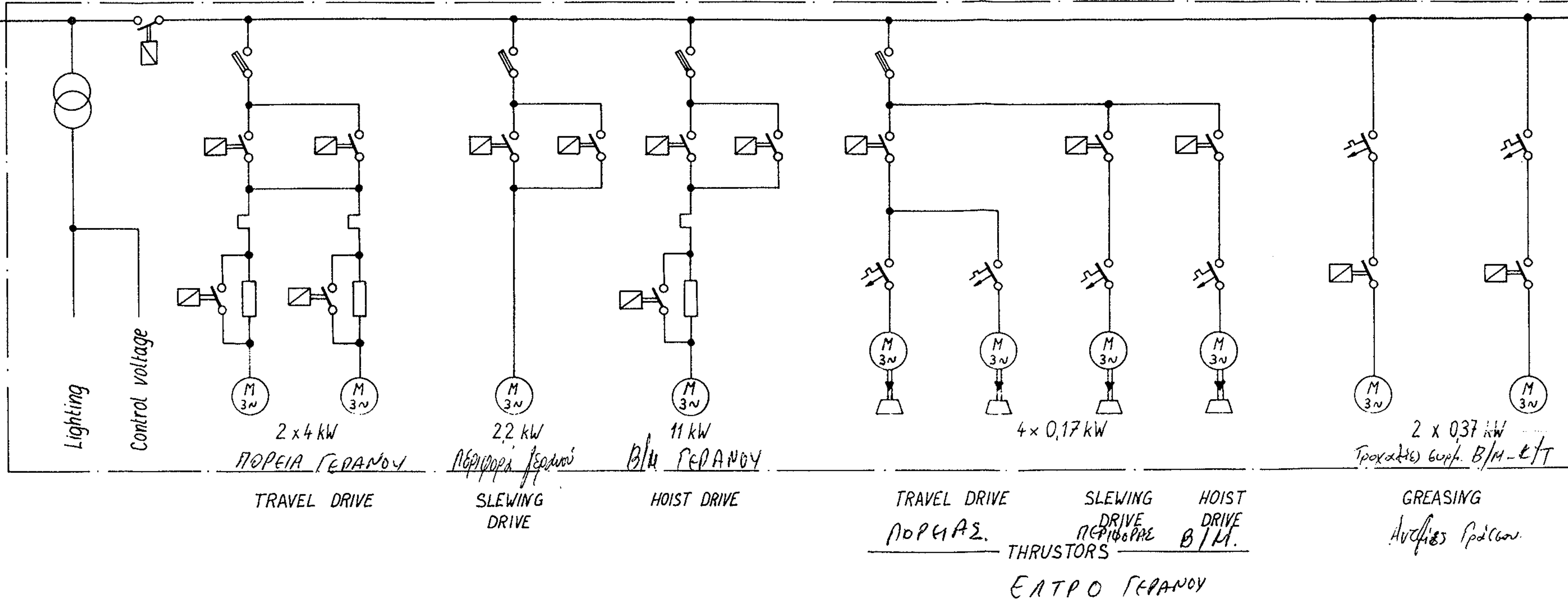

3 x 380V, AUX. BUSBAR "B" SUPER STRUCTURE



Contract-No: DMKO - 6 / 99045
 Consortium : TAKRAF - BBC

Drawn	Checked	Std checked	Re-leased
Derived from:	Super-sedes:	Superseded by:	Without sep. parts list <input type="checkbox"/>
A 83-12-20			Scale
S 84-01-30			Sep. PL same No. <input type="checkbox"/>
			Sep. PL other No. <input type="checkbox"/>
			Dept. resp.
Title			Doc. type
1-339 240			Format
B.W.E. SRs 2000			Lang.
SOUTH FIELD 2			Sh. No.
AUX. BUSBAR SUPERSTRUCTURE			No. sh.
HIBE 201040			

Für diese Unterlage behalten wir uns alle Rechte, auch für den Fall der Patenterteilung und der Eintragung eines anderen gewerblichen Schutzrechtes, vor. Missbräuchliche Verwendung, wie insbesondere Vervielfältigung und Weitergabe an Dritte ist nicht gestattet, sie kann zivil- und strafrechtlich geahndet werden.

HIBE 201040

0 50 100